



## Cold Air Blower For Airport Applications

- ▶ Clears runway lights in seconds
- ▶ Reduces runway occupancy time
- ▶ Blows away snow, ice, FODs
- ▶ Evolutive design
- ▶ Removable from the carrier

Sourcewell  
Formerly NJPA

Awarded Contract

Contract #080818RPM



## An Evolutive Design

On the market for over 25 years, the AF1 cold air blower system has proven to be an effective snow and FODs fighting equipment, significantly reducing runway occupancy time and maintenance operation costs. The AF1 system is being chosen by an increasing number of airports in North America, Europe, and Asia.

With its 860 km/h (535 mph) wind velocity and 9,21 m<sup>3</sup>/s (19 500 cfm ) airflow, AF1 EVO removes fresh and packed snow around runway lights and airfield signs in seconds. It's an effective piece of equipment to clear away snow and ice from runways, taxiways, aprons and thus cutting down on broom usage.

In addition, the system efficiently maintains pavement surfaces and significantly reduces aircraft engine foreign object damages by blowing away dust and various FODs such as rocks, debris, shells, crack filling compounds, plastic and metal components.

The AF1 EVO model provides flexibility and increase equipment usability. It can be easily removed as a complete module from the carrier in order to use the truck with other seasonal maintenance tools.

## Self-Contained and Removable Module

The AF1 EVO is completely independent from the carrier and can be removed in less than 2 hours. The module includes:

- Wireless remote control command system
- Separated hydraulic system
- Dedicated fuel and DEF tanks
- Support legs



## Multipurpose Carrier

The Peterbilt 520, is a single axle, rugged utility carrier that can be put at work all year round when equipped with other deck truck equipment such as:

- Liquid tanks
- De-icer spreader
- Lifting cranes

## Nozzle Positioning for Working and Traveling Modes



### Working Mode

- The adjustable nozzle is positioned in front
- Automatic sweeping operation mode or controlled by a joystick
- Maximum speed of 40 km/h (25 mph)



### Traveling Mode

- The nozzle is stowed and locked in the rear
- Automatic positioning of the nozzle for traveling between sites
- Maximum speed of 90 km/h (56 mph)



## Operator Safety

The AF1 EVO includes many features reducing risks of accidents such as:

- Doesn't require additional personnel on the ground to guide operations
- Access to regular maintenance items from a catwalk with railing
- A smart level analysis system prevents the vehicle to turn over on its side if imbalanced conditions occur

## Ideal to Maintain:

- Runway elevated lights (single and cluster)
- Runway insert lights
- Airfield signs
- Runways
- Taxiways
- Aprons

## 8 Hours of Fuel Autonomy

The blower module has its own fuel tank, independent from the carrier.

- Avoid accidental carrier running-on-empty situations
- Increase productivity



## Ideal to Clear:

- Snow
- Ice
- Dust
- Rocks / rubble
- Mollusk shells
- Organic debris
- Plastic components
- Metal components
- Crack filling compounds



## High Efficiency Design

The powerful air jet is generated by a three-stage high-performance centrifugal fan driven by a diesel engine via a clutch.

- Complete power transmission from the engine
- Require less maintenance
- Lower fuel consumption

## RPM Tech Advantages:

- Heavy duty construction
- Engine application audited by Caterpillar®
- Weather-resistant electrical components
- Original designer of cold air blowers. The first model was introduced in 1985
- More than 55 years of experience designing and manufacturing snow-removal equipment

## Intuitive Operation

The large display screen gives the operator a fast read of the cold air blower's operating parameters. An easy-to-use joystick controls the nozzle movements and airflow.



# AF1 EVO Technical Specifications

## Nozzle Vertical Mobility

From 76 to 914 mm  
(3 to 36 in.) above ground

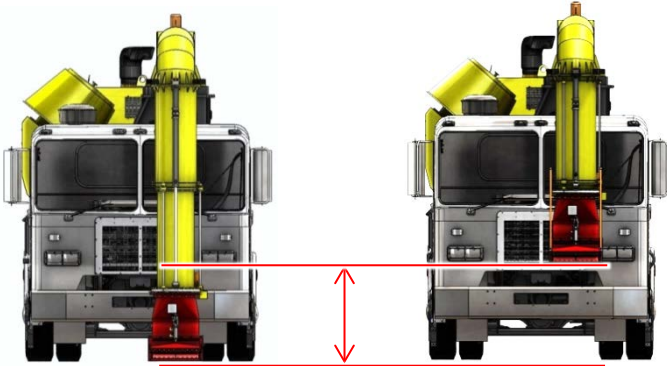

## Clearing Envelope

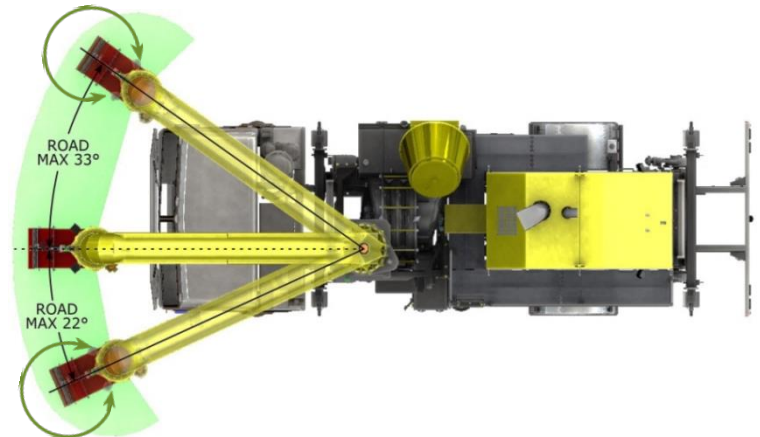

## AIR SPEED

- Up to 860 km/h (535 mph)

## AIRFLOW

- Created by a three-stage centrifugal high-performance blower
- Up to 9,21 m<sup>3</sup>/s (19,500 CFM)

## AIR NOZZLE MANEUVERABILITY

- Can be directed left or right
- Variable nozzle angles of attack
- Can be raised from 76 to 914 mm (3 to 36 in.) above ground
- Hydraulically controlled
- Automatic sweeping operation mode

## OPERATING SPEED

- 0 - 90 km/h (0 - 56 mph) traveling between sites
- 0 - 40 km/h (0 - 25 mph) optimal operating speed



## BLOWER POWER GROUP

- 310 kW (416 hp) Caterpillar® C9.3 turbocharged, Tier 4 Final Diesel engine with electronic regulators
- Fuel tank capacity: 348 L (92 gal)
- Industrial gear box
- Multi-disc clutch with a speed increaser

## MULTI-PURPOSE CARRIER

- Peterbilt 520
- Single axle, compliant to axle load:
  - 8165 kg (18000 lbs) on the front axle
  - 10433 kg (23000 lbs) on the rear axle

## DIMENSIONS (Transport mode)

- Overall width: 2540 mm (100 in.)
- Overall height: 3820 mm (150 3/8 in.)
- Overall length: 8179 mm (322 in.)

## UNIT WEIGHT

- 14 515 kg (32 000 lbs) approx.

RPM Tech Inc. reserves the right to change specifications and design features without notice.

Contact your representative for full details



2220 Michelin Street  
Laval, QC, H7L 5C3 Canada

Tel.: +1 450.687.3280  
1 800.631.9297  
(North America)

info@rpmtechgroup.com